

ISOMETER® iso165C...

Insulation Monitoring Devices (IMD)

for unearthed DC drive systems (IT systems) in electric vehicles





ISOMETER® iso165C

Device features

- Insulation monitoring of AC and DC insulation faults for unearthed systems (IT systems) from 0...600 V peak
- Power supply for all internal voltages
- Continuous measurement of insulation resistance from 0 Ω...50 MΩ
- Response time of ≤ 20 s for measured insulation resistance (using Direct Current Pulse (DCP))
- Automatic adaptation to the existing system leakage capacitance (≤ 1 μF)
- Detection of ground faults and lost ground line
- Measurement of a second voltage
- The device works when:
 - HV is unstable
 - HV is powered off
 - There are symmetric or asymmetric insulation faults
 - Faults exist between HV lines and the supply voltage
- Galvanic insulation of all signals from the HV side
- HV coupled network
- CAN bus interface
- Light weight: < 220 g (including housing and connection frame)
- **iso165C-1 only:** The iso165C-1 variant features **Error** and **Warning** signals on the separated high-side driver

Certifications



Product description

The ISOMETER® monitors the insulation resistance between the active HV components of an electrical drive system ($U_n = DC\ 0\ V...600\ V$) and the reference earth (chassis ground). The patented measurement technology is used to monitor the condition of the insulation on the DC side as well as on the AC motor side of the electrical drive system.

The ISOMETER® is assembled with three connectors. To achieve internal galvanic separation, connector 1 is connected to low-voltage (LV) areas and connectors 2 and 3 are connected to the HV areas in the car environment.

Due to its space saving design and optimized measurement technology, the device is optimized for use in hybrid or fully electric vehicles. The device meets the increased automotive requirements with regard to environmental conditions (e.g. temperatures and vibration, EMC). The ISOMETER® CAN bus interface allows it to integrate seamlessly into an existing CAN environment.

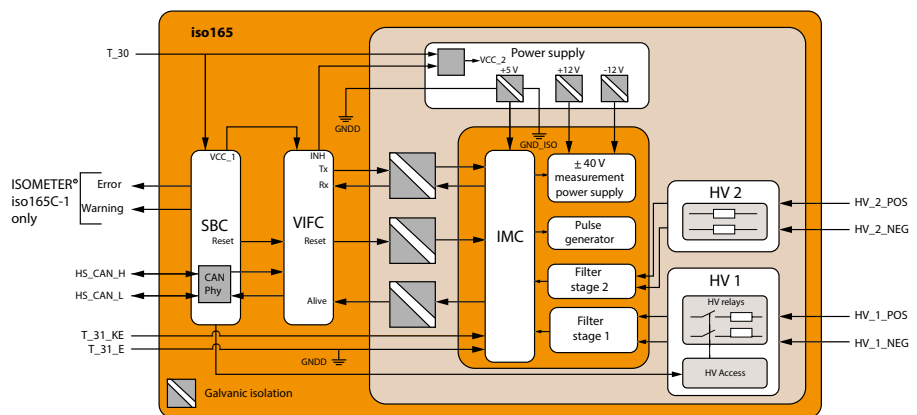

Function

The ISOMETER® iso165C and iso165C-1 consist of two main components, the Vehicle Interface Controller (VIFC) and the Insulation Monitoring Controller (IMC). The VIFC consists of a microcontroller with a UART communication interface that translates and forwards requests from the HS-CAN bus transparently to the IMC. The corresponding IMC responses are returned to the requesting instance via the HS-CAN bus. The VIFC supervises the running state of the IMC via a signal known as „Alive“, and internally and cyclically requests the insulation value and the running state of the IMC. The results are cyclically sent as an informal message via the HS-CAN bus.

The IMC consists of the HV connectors with HV coupling relays, the measurement circuit and a microcontroller to analyse the measurement results. It generates internal alarm information from the measurement results, which is coded to produce the „Alive“ signal mentioned previously. This signal is transmitted in parallel with the measurements and status information to the VIFC and from there over the HS-CAN bus. The IMC is galvanically separated from the car environment.

At initial power on, the ISOMETER® iso165C does not carry out any measurements until communication between the VIFC and IMC has been established. In addition, the HV coupling relays of the HV1 voltage path are, by default, open and therefore no valid measurement of voltage HV1 and the insulation resistance is possible until these relays are closed by an external command. Once these conditions have been satisfied, the ISOMETER® iso165C can immediately start measuring voltages HV1, HV2 and the insulation resistance.

In the ISOMETER® **iso165C-1**, however, the HV coupling relays of the HV1 voltage path are automatically closed at power on.

Function (continued)

The initial measurement values after power up are:

	HV relays open	HV relays closed
Insulation resistance	50,000 kΩ	Value in kΩ
Voltage of HV1	0V	Value in V
Voltage of HV2	Value in V	Value in V

The ISOMETER® generates a pulsed measuring voltage that is superimposed on the IT system by terminals T_31_E/KE (chassis). Because the connection between the terminals E/KE and the chassis ground (T_31) is continuously monitored, it is necessary to install two separated conductors from terminals T_31_E/KE to chassis ground.

Standards – corresponding norms and regulations

General

IEC 61557-8 2007-01; IEC 60664-1 2004-04; ISO 6469-3 2001-11; ISO 23273-3 2006-11

EMC

CISPR 25; ISO 7637-2; ISO 11452-4; ISO 11452-2; ISO 11452-8; ISO 10605; IEC 61326-2-4; IEC 61000-4-4; E1 acc. 72/245/EWG/EEC; ISO 16750-2

Environmental

ISO 16750-1; ISO 20653; ISO 16750-3; IEC 60068-2-14; IEC 60068-2-27; IEC 60068-2-32; IEC 60068-2-64; ISO 16750-4; IEC 60068-2-1; IEC 60068-2-2; IEC 60068-2-38; IEC 60068-2-60; IEC 60068-2-78

Normative exclusion

The device has gone through an automotive test procedure in accordance with multi customer requirements as outlined by reg. ISO 16750-x. IEC 61557-8 will be fulfilled by creating an LED warning function and test button at the customer site if necessary.

Enclosure and mounting

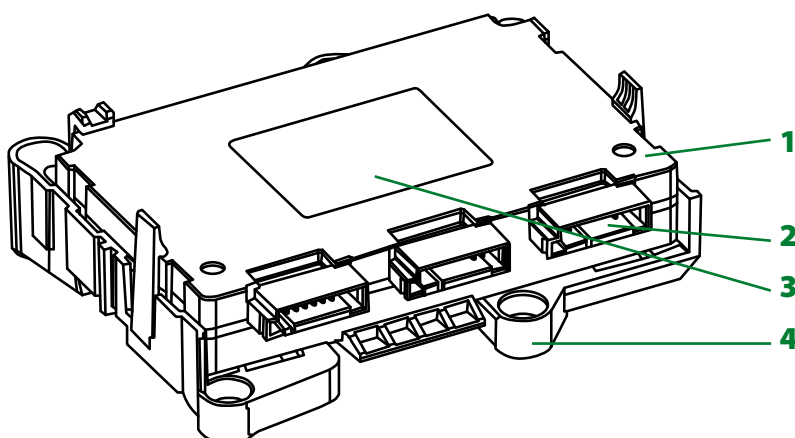

- 1 - Enclosure PBT GF30 black, UL Standard: UL94 V0
- 2 - Connector pin Cu-alloy, tin plated

ISOMETER® iso165C and ISOMETER® iso165C-1 comparison

While the ISOMETER® iso165C and ISOMETER® iso165C-1 are similar in many aspects the main differences between the two are shown in the table below:

Feature	iso165C	iso165C-1
Contains an output driver	No	Yes. Error and Warning signals are available on the separated high-side driver
Coupling relays at power on	The HV coupling relays of the HV1 voltage path are, by default, open and therefore no valid voltage and insulation resistance measurements are possible until these relays are closed, which must be carried out using an external command	The HV coupling relays of the HV1 voltage path are automatically closed at power on
Baud rate	250 kBaud	500 kBaud
Terminating resistance	124 Ω internally	None

Section view A-A
Scale: 2:1

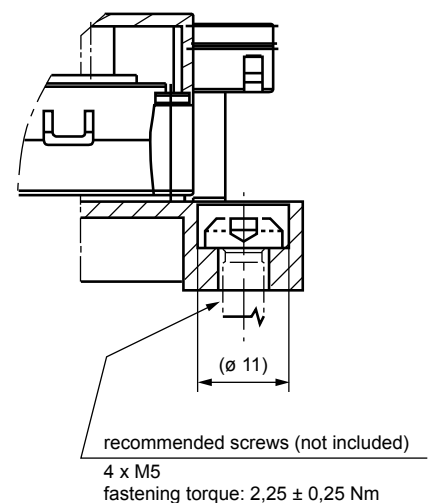

- 3 - Label White Polyester foil
- 4 - Bracket PBT GF30 black, UL Standard: UL94 V0

Connectivity

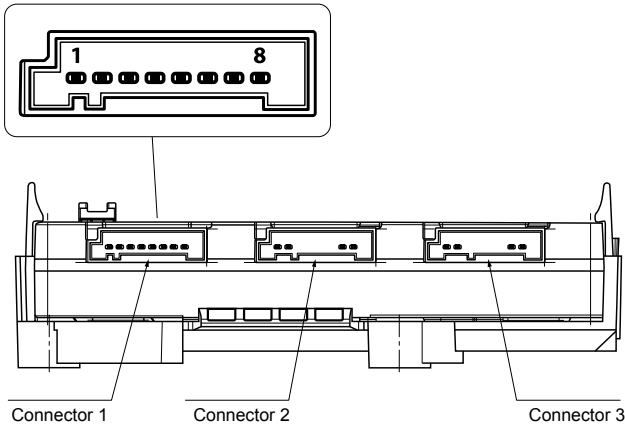

Connector ¹⁾	Type	Code	Colour
1	1719183-1	A	Black
2	1719183-2	B	White
3	1719183-3	C	Blue

¹⁾ Please refer to „Technical Data“ for detailed connector information.

Typical application

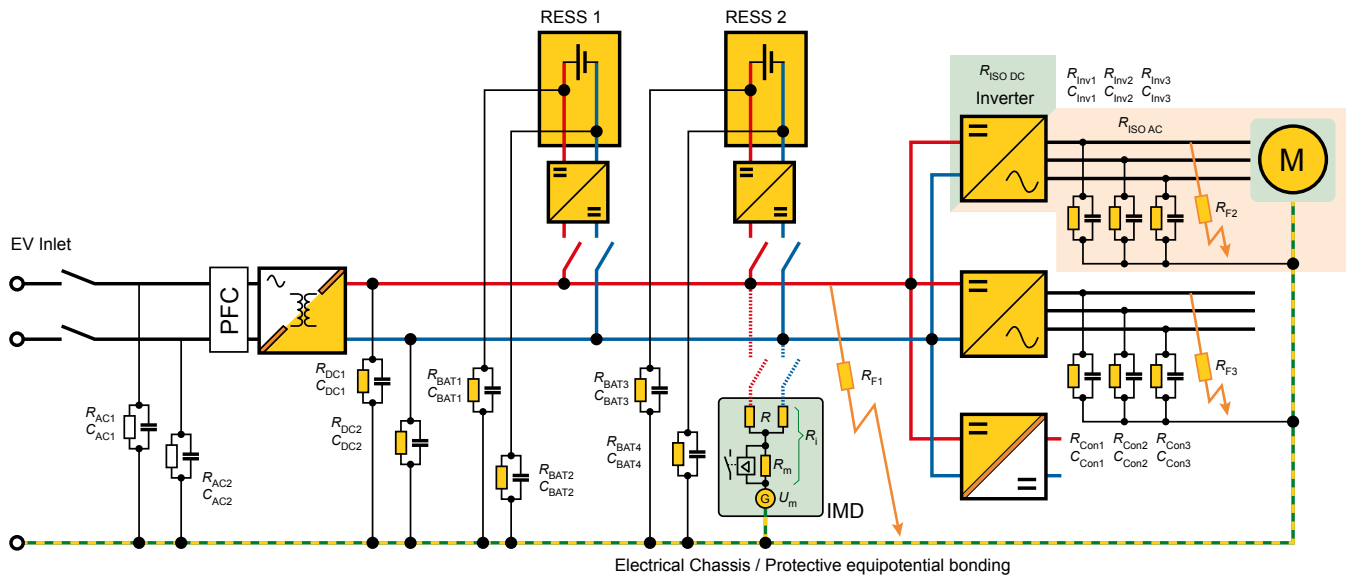

Ordering information

Response value range	Nominal voltage		Supply voltage		Type	Art. No.
	DC	DC	DC	DC		
Alarm 1 (Warning): 30 kΩ ... 1 MΩ (default: 300 kΩ); Alarm 2 (Error): 40 kΩ ... 2 MΩ (default: 55 kΩ)	0 ... 600 V		12 V		iso165C	B91068175
Alarm 1 (Warning): 30 kΩ ... 1 MΩ (customer setting: XXX kΩ); Alarm 2 (Error): 40 kΩ ... 2 MΩ (customer setting: XXX kΩ)	0 ... 600 V		12 V		iso165C	B91068175C
Alarm 1 (Warning): 30 kΩ ... 1 MΩ (default: 400 kΩ); Alarm 2 (Error): 40 kΩ ... 2 MΩ (default: 250 kΩ)	0 ... 600 V		12 V		iso165C-1	B91068176
Alarm 1 (Warning): 30 kΩ ... 1 MΩ (customer setting: XXX kΩ); Alarm 2 (Error): 40 kΩ ... 2 MΩ (customer setting: XXX kΩ)	0 ... 600 V		12 V		iso165C-1	B91068176C

Accessories

Type	Art. No.
iso165C connecting kit	B91068503

Technical data
Supply voltage

Supply voltage U_S	DC 9...16 V
Nominal supply voltage	DC 12 V
Max. operational current I_S	300 mA (typ. 185 mA)
Max. current I_K	5 A
Power dissipation P_S	< 2.5 W

Supervised IT system

Rated voltage range U_n	DC 0...600 V
Tolerance	+15 %
Frequency range	10 Hz...1 kHz
System leakage capacitance C_e	≤ 1 μF
Withstand voltage test	AC 1.9 kV/1 min

Measuring circuit

Measurement method	Bender DCP technology
Measuring voltage U_m	±40 V
Measuring current I_m at $R_F = 0$	±33 μA
Impedance Z_i at 50 Hz (HV1)	≥ 1.2 MΩ (≥ 2.4 MΩ each, each line, high resistance in off state)
Internal resistance R_i (HV1)	≥ 1.2 MΩ (≥ 2.4 MΩ each, each line, high resistance in off state)
Impedance Z_i at 50 Hz (HV2)	≥ 10.5 MΩ (≥ 21 MΩ each line)
Internal resistance R_i (HV2)	≥ 10.5 MΩ (≥ 21 MΩ each line)

Measuring ranges

Insulation resistance range	0 Ω...50 MΩ
Insulation resistance duration/Pulse (normal operation)	~ 1.6 s (≤ 1 μF/0 MΩ) ~ 6 s (≤ 1 μF/10 MΩ)
Relative error (DCP)	100 kΩ...5 MΩ, ±15 %
Absolute error (DCP)	0 Ω...100 kΩ, ±15 kΩ
High-voltage range	0...600 V
High-voltage tolerance	0...100 V, ±5 V 100...600 V, ±5 %

High-side driver output (iso165C-1)

HST_1*	High-side driver 1, iso Warning
Maximum current, I_{out_max}	80 mA
HST_2*	High-side driver 2, iso Error
Maximum current, I_{out_max}	80 mA

Response values
iso165C

Response value Alarm 1 (Warning)	30 kΩ...1 MΩ (default: 300 kΩ)
Response value Alarm 2 (Error)	40 kΩ...2 MΩ (default: 55 kΩ)

iso165C-1

Response value Alarm 1 (Warning)	30 kΩ...1 MΩ (default: 400 kΩ)
Response value Alarm 2 (Error)	40 kΩ...2 MΩ (default: 250 kΩ)

iso165C und iso165C-1

Response uncertainty (according to IEC 61557-8)	±15 %
Hysteresis	+25 %
Factor averaging F_{ave}	1...10 (default: 3)
Response time t_{an} (DCP)	$t_{an} \leq 20$ s (at $F_{ave} = 10^{**}$) during self test $t_{an} + 10$ s
Measurement time after power on (and after HV relays are closed)	≤ 3 s (< 1 μF/150 kΩ)
Switch-off time t_{ab} (DCP)	$t_{ab} \leq 40$ s (at $F_{ave} = 10$) during self test $t_{ab} + 10$ s

Interface

Protocol	HS-CAN
----------	--------

iso165C

Data rate	250 kBaud
Terminating resistance	124 Ω internally

iso165C-1

Data rate	500 kBaud
Terminating resistance	None

Environment/EMC

EMC	IEC 61326-2-4
Overvoltage category/degree of pollution	II/2
Temperature range	-40...+85 °C
Range of application	5,000 m above sea level

Connectors (Tyco)

Receptacle housing type	1719183-1, 1719183-2, 1719183-3 (black, white, blue)
Receptacle drawing number	C-1719183
Contact type (tin plated)	5-963715-1
Contact wire range	0,50...0,75 mm ²
Contact drawing number	929454
Crimp hand tool	539635-1

Other

Operating mode	Continuous operation
Degree of protection	IP5K0

Software version

iso165C	V1.0 - Release S010 (VIFC: V5.0, IMC V5.0)
iso165C-1	V2.0 - Release S010 (VIFC: V10.0, IMC V5.0)

Mounting

Recommended screws for mounting	4 x M5 (not included)
Max. tightening torque	2.25 ± 0.25 Nm (XX lbs-in)

* External 2.2 kΩ pull-down resistor to chassis ground (KL31) is required.
Not protected against a short circuit in the event that KL31 is missing.
Therefore, a 100 Ω resistor is required on each driver output.

** $F_{ave} = 10$ is recommended for electric vehicles

Dimension diagram

Dimensions in mm

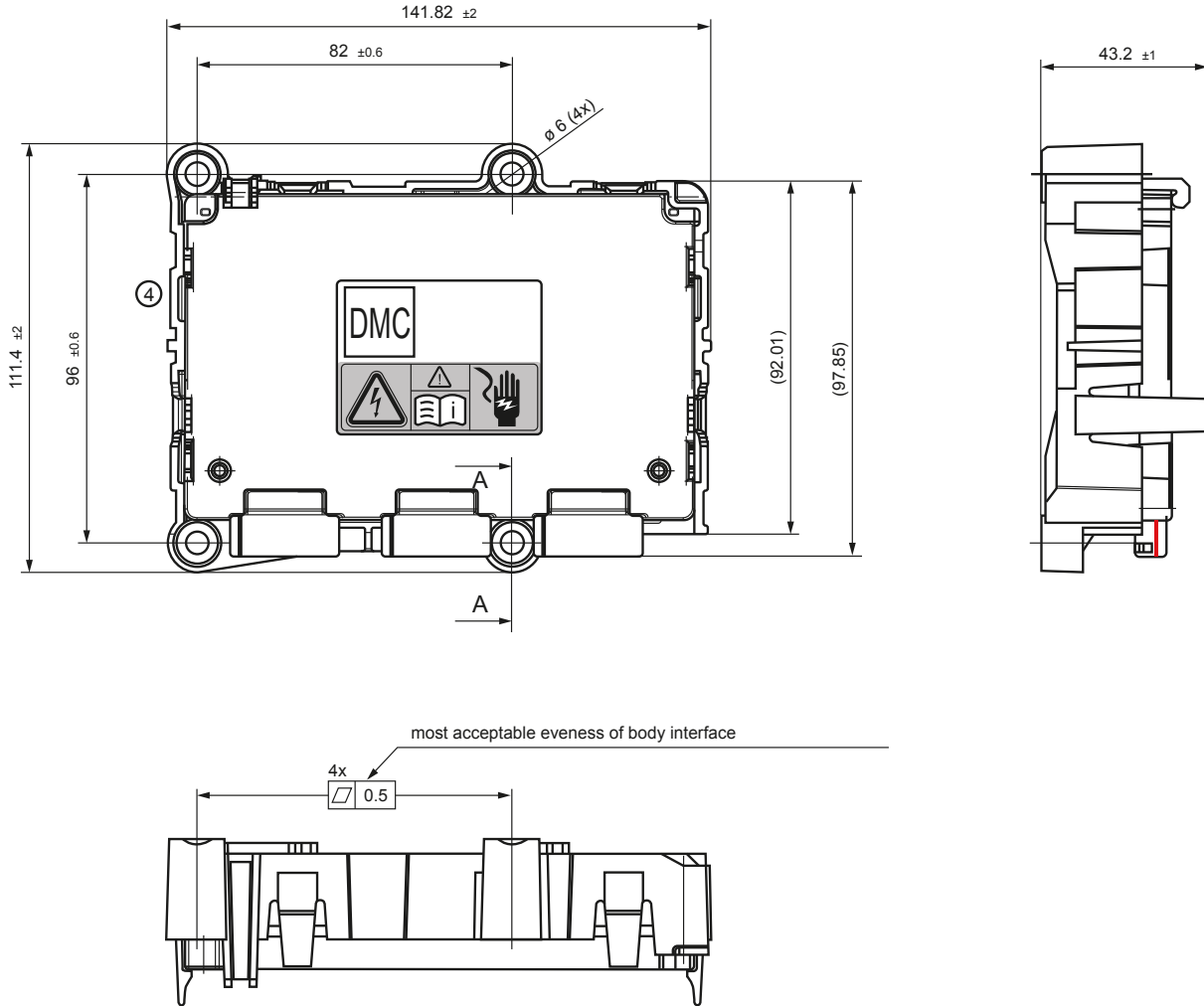

<p>CAPTECH  POWER QUALITY SOLUTIONS</p>	<p>Distributed in Australia by: Captech Pty Ltd Phone: 1300 280 010 Email: sales@captech.com.au</p>
---	---



Bender GmbH & Co. KG
 P.O. Box 1161 • 35301 Gruenberg • Germany
 Londorfer Strasse 65 • 35305 Gruenberg • Germany
 Tel.: +49 6401 807-0 • Fax: +49 6401 807-259
 E-Mail: info@bender.de • www.bender.de



BENDER Group